

Dear Distributor,

In order to make the adjustment of lower diffuser accurate easy, the pitch of threads of diffuser ring, studs and nuts were changed from 2,0 to 1,5 (M16) and 2,5 to 1,5 (M20) threads.

The following part numbers were changed accordingly:

Diffuser ring N part No. 50 383 00 to 50 383 01 pos. **96**

Diffuser ring H part No. 50 380 00 to 50 380 01 pos. **96**

Diffuser ring L part No. 50 386 00 to 50 386 01 pos. **96**

Stud for N & L model part No. 132425 to 50 024 03
dimension M16x1,5x100 pos. **105**

Stud for H model part No. 50 025 04 to 50 025 06
dimension M20x1,5x110 pos. **105**

Nut for N & L model part No. 132256 to 50 024 04
dimension M16x1,5 pos. **106 & 110**

Nut for H model part No. 50 025 00 to 50 025 07
dimension M20x1,5 pos. **106 & 110**

Date of change 2000.09, see spare parts list revision 2.

The cover plate for lower bearing part No. 50 417 00 pos. **77** was removed.

The bearing holder part No. 50 418 00 pos. **82** was replaced by part No. 50 418 02. Design change of the holder is the depth of space for lower bearing that was reduced from 73,0 mm to 72,5 mm to fit together with the circlip ring part No. 50 279 00 pos. **76** in the bearing holder.

Date of change 2001 01, see spare parts lists revisions 1 and 3.

A white plastic washer part No. 50 595 00 pos. **95** was introduced on the shaft end between the impeller adjusting washers and V-rubber seal for rotating seal ring of lower shaft seal. The purpose of the washer is to balance the force on V-rubber seal. Date of change 2002 10, see spare parts list revision 5.

To fit diffuser ring pos. **97**, holder part No. 50 54100 pos. **101** and ten washers part No. 132 258 pos. **98** are being used. The numbers of washers will be adjusted accordingly in next revision of spare parts list. Date of change 2003 01.

For details see page 2.

Yours faithfully

Sören Eriksson
Technical Manager

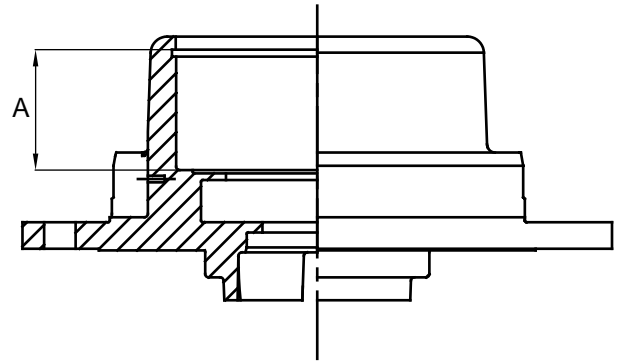
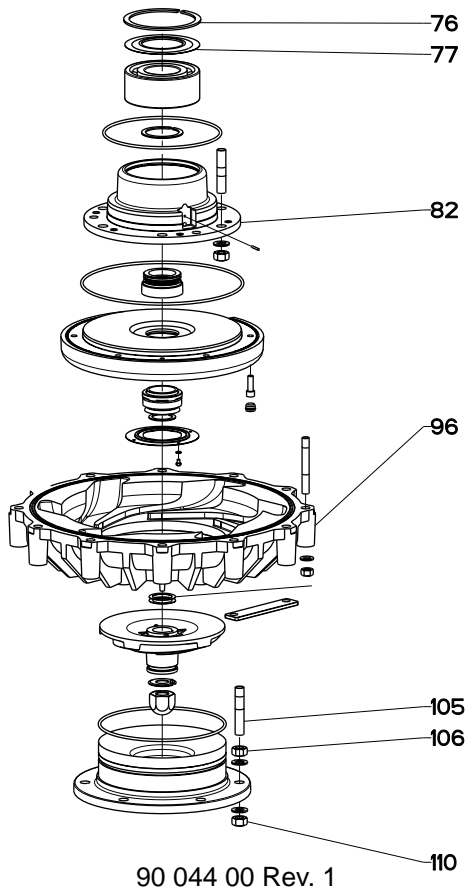

A = 72,5 mm
Bearing holder, part No 50 418 02

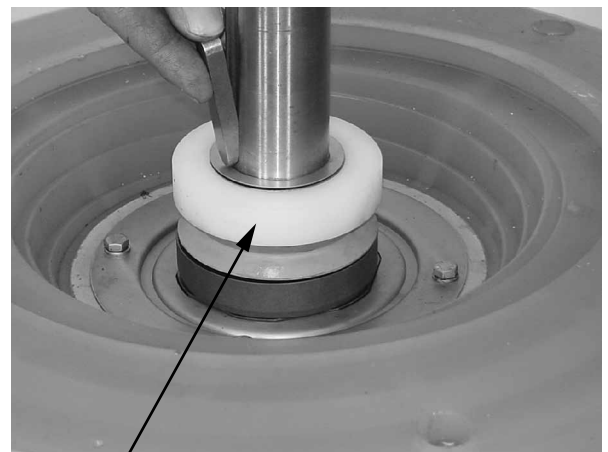
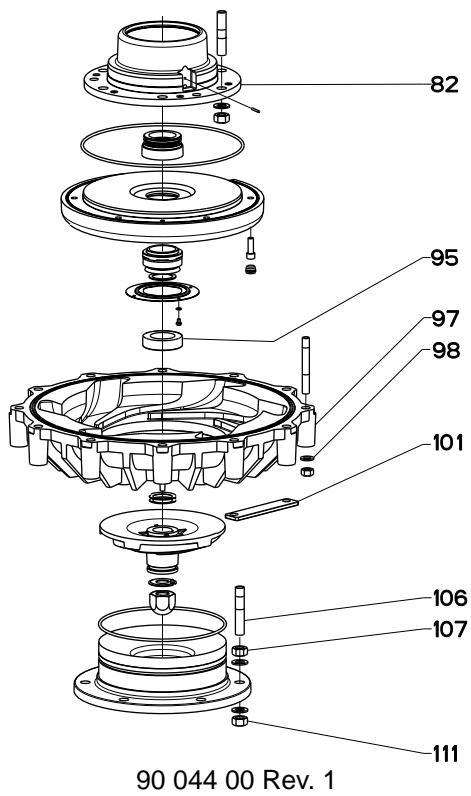

Washer, part No 50 595 00