

Installation, care and maintenance



www.grindex.com

MEGA



CONTENTS

Data plate interpretation _____	4	Operation _____	15
Safety _____	5	Before starting _____	15
Product description _____	6	Cleaning _____	15
Applications _____	6	Care and maintenance _____	15
Motor data _____	6	Safety precautions _____	15
Dimensions and weights _____	7	Inspection _____	15
Design _____	8	Recomended inspections _____	16
Transportation and storage _____	9	Changing the oil _____	17
Installation _____	9	Replacing the impeller _____	17
Safety precautions _____	9	Fault tracing (Troubleshooting) ____	26
Pump installation _____	9	Accessories and tools _____	29
Electrical connections _____	10	Service log _____	30

DATA PLATE INTERPRETATION

GENERAL DATA PLATE

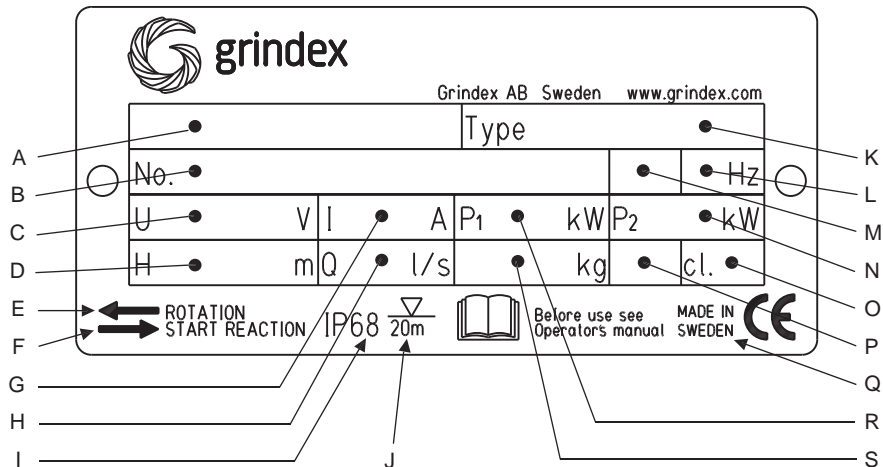

Data plate interpretation

- A Pump model
- B Serial No.
- C Rated voltage
- D Maximum height
- E Direction of impeller rotation
- F Direction of start reaction
- G Rated current
- H Maximum capacity
- I Degree of protection
- J Maximum submersion depth
- K Pump type No.
- L Frequency
- M Phases, type of current
- N Rated shaft power
- O Thermal class
- P Locked rotor code letter
- Q Country of origin
- R Maximum power consumption
- S Weight

SAFETY



- Only Ex-approved pumps may be used in an explosive or flammable environment.
- Before starting work on the pump, make sure that the pump and the control panel are isolated from the power supply and can not be energized. This applies to the control circuit as well.
- Thermal contacts must be connected to protection circuit intended for that purpose according to the approval of the product.
- The pump may be used only in accordance with the approved motor data stated on the data plates.
- This equipment must be installed in conformity to prescriptions in international or national rules (IEC/EN 60079-14).
- The maintenance operation must be made in conformity to the international or national standards (IEC/EN 60079-17).
- The yield stress of fastener elements in the product must be in conformity with the value specified in the table for “Material of fastener” on the approval drawing or the parts specified in the part list for the product.
- Grindex disclaims all responsibility for work done by untrained, unauthorized personnel.

PRODUCT DESCRIPTION

Applications

MEGA are intended to be used for:

- pumping of water which may contain abrasive particles.
- pumping of raw or clean water.
- pumping of ground water.

MEGA are available in the following versions:

N = Medium-head with an open, double suction radial-flow impeller.

H = High-head with two closed radial-flow impellers.

Liquid temperature: max. 40°C (105°F)

Liquid density: max. 1100 kg/m³ (9.2 lb per US gal.)

The pumped liquid may contain particles up to a size which corresponds to the openings in the strainer.

The pH of the pumped liquid: 6—13.

Depth of immersion: max. 75 m (250 ft).

For specific data regarding your pump, please see Part List.

Motor data

3 ~ 50 Hz, 2955 r/min

Rated output: 90 kW

Max consumption: 95 kW

Voltage V	Rated current A	Starting current A
380	155	1170
400	149	1255
415	142	1075
440	136	1140
500	118	825
525	113	885
550	109	915
1000	60	475

3 ~ 60 Hz, 3560 r/min

Rated output: 104 kW, (140 hp)

Max consumption: 110 kW (148 hp)

Voltage V	Rated current A	Starting current A
380	179	1195
400	170	1260
440	155	1145
460	149	1105
575	118	850
600	113	840

DIMENSIONS & WEIGHTS

N-version

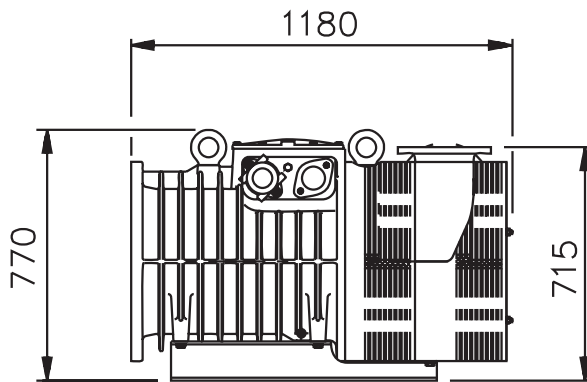

H-version

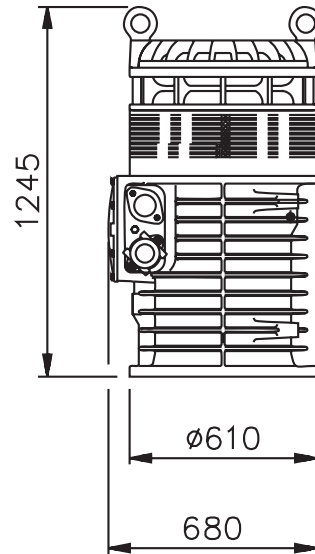

Weight without motor cable:

N 900 kg (1984 lbs)

H 985 kg (2172 lbs)

DESIGN

1. Motor

Squirrel-cage 3-phase induction motor for 50 Hz or 60 Hz.

The motor is started by means of direct-on-line start.

The motor can be run continuously or intermittently with a maximum of 15 evenly spaced starts per hour.

The stator is insulated in accordance with class H (180°C, 356°F). The motor is designed to supply its rated output at $\pm 5\%$ variation of the rated voltage. Without overheating the motor, $\pm 10\%$ variation of the rated voltage can be accepted provided that the motor does not run continuously at full load. The motor is designed to operate with a voltage imbalance of up to 2% between the phases.

2. Bearings

The pump bearings are designed for at least 20 000 hours of operation.

The main bearing of the rotor consists of two single row angular contact ball bearings.

The support bearing consists of one roller bearing.

When changing the bearings, and pre-greased bearings are not used, 260 g grease should be filled in the main bearings and 30 g grease in the support bearing.

Grease Mobilith SHC 220 or equivalent should be used.

3. Oil casing

The oil lubricates and cools the seals and acts as a buffer between the pump casing and the electric motor.

Pressure build-up within the oil casing is reduced by means of a built-in air volume.

4. Shaft seals

The pump has two mechanical seals which provide the isolation necessary between the electric motor and the pumped liquid.

Inner seal: Tungsten carbide-Tungsten carbide
Outer seal: Tungsten carbide-Tungsten carbide

5. Shaft

The shaft is delivered with the rotor as an integral part.
Shaft material: Stainless steel

6. Impellers

The pump is available with the following types of impellers:

- one double-suction radial-flow impeller of chromium alloyed cast iron (N), or
- two radial-flow impellers of nodular iron or heat-treated chromium alloyed cast iron (H).

Monitoring equipment

Three thermal switches are incorporated in the stator. The resistance of the thermal contacts changes at 125°C (260°F), close at 95°C (200°F).

The monitoring equipment shall be of a design that makes automatic restart impossible.

Bearing temperature is also monitored by means of a Pt100 transducer.

See also "Electrical connections" and separate instructions for starters.

Cooling

The stator is cooled by the surrounding liquid.

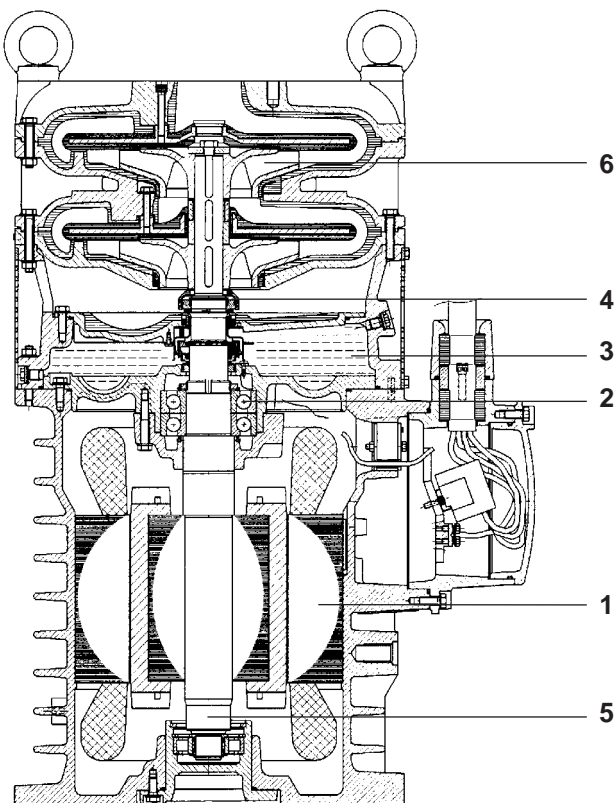

NOTE!
Make sure that the monitoring equipment incorporated in the product is correctly connected.

TRANSPORTATION AND STORAGE

The pump may be transported and stored in a vertical or horizontal position. Make sure that it cannot roll or fall over.



Warning!
Always lift the pump by its lifting eyes, never by the motor cable or the hose.

The pump is frostproof as long as it is operating or is immersed in the liquid. If the pump is taken up when the temperature is below freezing, the impeller may freeze. The pump shall be operated for a short period after being taken up in order to expel all remaining water.

A frozen impeller can be thawed by allowing the pump to stand immersed in the liquid for a short period before it is started. Never use a naked flame to thaw the pump.

For longer periods of storage, the pump must be protected against moisture and heat. The impeller should be rotated by hand occasionally (for example every other month) to prevent the seals from sticking together. If the pump is stored for more than 6 months, this rotation is mandatory.

After a long period of storage, the pump should be inspected before it is put into operation. Pay special attention to the seals and the cable entry.

Follow the instructions under the heading "Before starting".

INSTALLATION

Safety precautions

In order to minimize the risk of accidents in connection with the service and installation work, the following rules should be followed:

1. Make sure the lifting equipment is in good condition.
2. Be aware of the risk of electrical accidents.
3. Use a safety helmet, safety goggles and protective shoes.
4. Do not ignore the risk of drowning.
5. A first aid kit must be available.



At certain installations and operation points on the pump curve the noise level 70 dB, or for the actual pump specified noise level, can be exceeded.

Pump installation

Run the cables so that they do not have any sharp bends and are not pinched.

Connect the discharge connection and motor cable. See "Electrical connections".

Lower the pump into the sump.

Place the pump on a base which will prevent it from sinking into a soft sump bottom. Alternatively, the pump can be suspended by its lifting eyes just above the sump bottom.

Consult your nearest Grindex representative regarding:

- choice of ancillary equipment.
- other problems in connection with installation.

ELECTRICAL CONNECTIONS

If the pump is delivered without an installed motor cable, or if there is need for any modifications or repairs, please note that all electrical work shall be carried out under the supervision of an authorized electrician.

Local codes and regulations shall be complied with.



WARNING!
All electrical equipment must be earthed. This applies to both pump equipment and any monitoring equipment. Failure to heed this warning may cause a lethal accident. Make sure that the earth lead is correctly connected by testing it.

Check that the mains voltage and frequency agree with the specifications on the pump data plate.

The motor can only be connected for different voltages by authorized work shop.

Under no circumstances may the starter equipment be installed in the pump pit.

If intermittent operation is prescribed (see data plate), the pump shall be provided with control equipment that provides such operation.

To avoid leakage into the pump, check:

- that the cable entry seal sleeve and washers conform to the outside diameter of the cable. See the parts list.
- that the outer jacket on the cable is not damaged. When refitting a cable which has been used before, always cut off a short piece of the cable so that the cable entry seal sleeve does not close around the cable at the same point again.



NOTE!
For safety reasons, the earth lead should be longer than the phase leads. If the motor cable is jerked loose by mistake, the earth lead should be the last lead to come loose from its terminal. This applies to both ends of the cable.

Check on the data plate which connection, Y or Δ , is valid for the voltage supply. Then, depending on voltage, arrange the connection on the terminal board in accordance with Y or Δ , see figure.

Connect the motor cable to the terminal board connections U1, V1, W1 and earth.

Make sure that the pump is correctly earthed (grounded).

Tighten the screws so that the cable entry unit bottoms out.

Install the cover.

Connect the motor cable to the starter equipment. Check the direction of rotation, see "Before starting".

If the direction of rotation is wrong, transpose two of the phase leads.

Three thermal contacts are incorporated in the stator.

Remember that the starting surge with the direct-on line start can be up to six times higher than the rated current. Make sure that the fuses or circuit breakers are of the proper amperage.

The table on page 4 gives rated current and starting current. Fuse amperage and cable shall be selected in accordance with local rules and regulations. Note that with long cables, the voltage drop in the cable must be taken into consideration, since the motor's rated voltage is the voltage that is measured at the terminal board in the pump.

The overload protection in the external starter (motor protection breaker) shall, for direct-on-line start be set to the motor's rated current as given on the data plate.



NOTE!
Make sure that the monitoring equipment incorporated in the product is correctly connected.

Connection plate

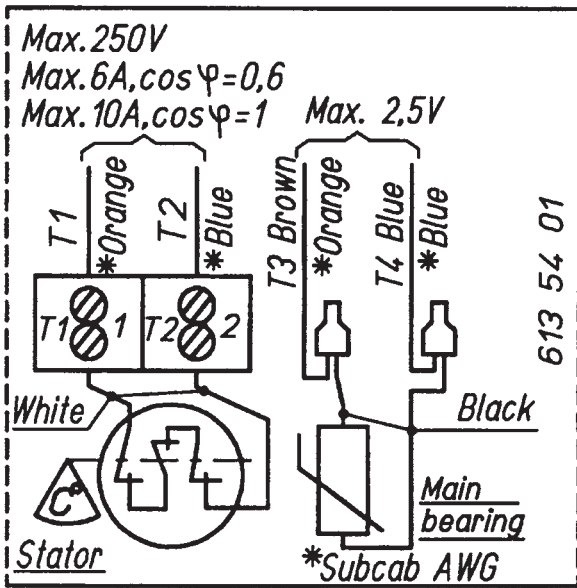

CABLE CHART

SUBCAB® 4GX/SUBCAB® AWG, 6-leads, Y



Bild 49a

SUBCAB® 4GX/SUBCAB® AWG, 6-leads, D

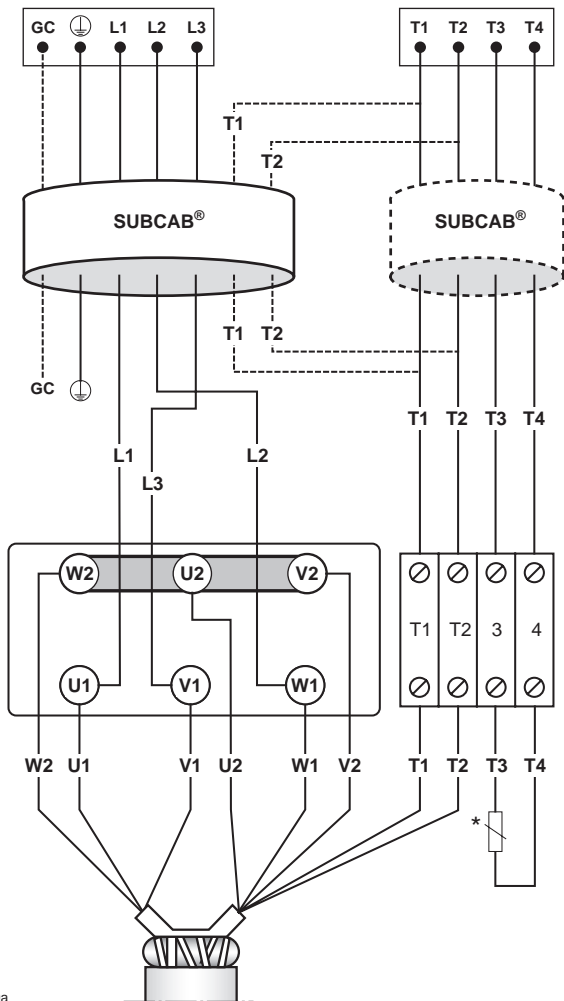

Bild 45a

Mains	SUBCAB® Lead	SUBCAB® AWG Lead	Terminal board
L1	brown	red	U1
L2	black	black	W1
L3	grey	white	V1
⊕	yellow/green	yellow/green	⊕
Groundcheck GC	yellow	yellow	
Control	SUBCAB® Cable lead	SUBCAB® AWG Cable lead	Terminal board
T1	T1	orange	T1
T2	T2	blue	T2
T3	T3	orange	3
T4	T4	blue	4
Stator leads connection:			
Stator lead	Terminal board		
U1, red	U1		
W2, black	W2		
V1, brown	V1		
U2, green	U2		
W1, yellow	W1		
V2, blue	V2		
*Pt100, Main bearing			

Mains	SUBCAB® Lead	SUBCAB® AWG Lead	Terminal board
L1	brown	red	U1
L2	black	black	W1
L3	grey	white	V1
⊕	yellow/green	yellow/green	⊕
Groundcheck GC	yellow	yellow	
Control	SUBCAB® Cable lead	SUBCAB® AWG Cable lead	Terminal board
T1	T1	orange	T1
T2	T2	blue	T2
T3	T3	orange	3
T4	T4	blue	4
Stator leads connection:			
Stator lead	Terminal board		
U1, red	U1		
W2, black	W2		
V1, brown	V1		
U2, green	U2		
W1, yellow	W1		
V2, blue	V2		
*Pt100, Main bearing			

CABLE CHART

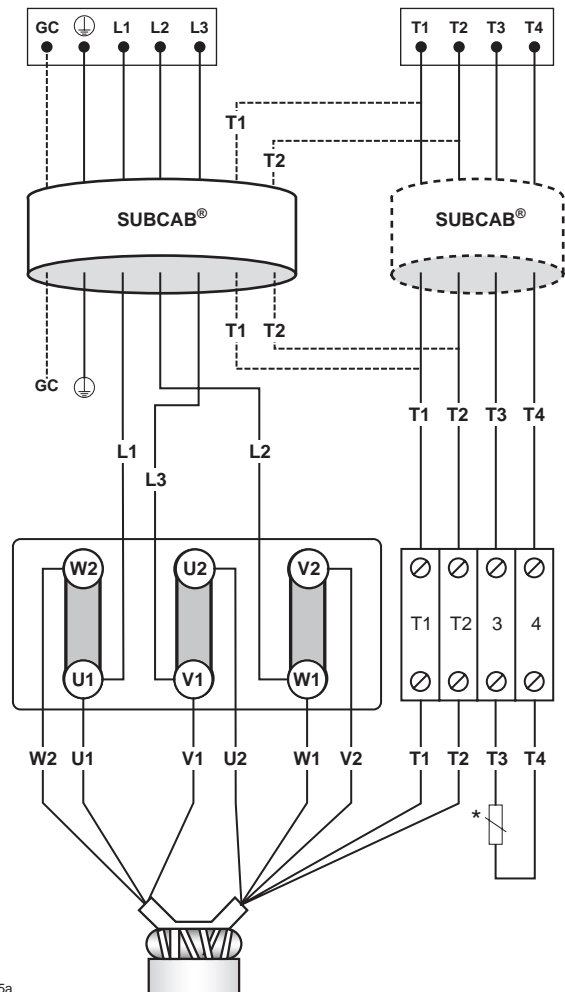
SUBCAB® 4GX/SUBCAB® AWG, 6-leads, YD



Bild 56a

Mains	SUBCAB® Lead	SUBCAB® AWG Lead	Terminal board
L1	brown	red	U1
L2	black	black	W1
L3	grey	white	V1
L1	brown	red	W2
L2	black	black	V2
L3	grey	white	U2
⊕	yellow/green	yellow/green	⊕
Groundcheck GC		yellow	
Control	SUBCAB® Cable lead	SUBCAB® AWG Cable lead	Terminal board
T1	T1	orange	T1
T2	T2	blue	T2
T3	T3	orange	3
T4	T4	blue	4
Stator leads connection:			
Stator lead		Terminal board	
U1, red		U1	
W2, black		W2	
V1, brown		V1	
U2, green		U2	
W1, yellow		W1	
V2, blue		V2	
*Pt100, Main bearing			

SCREENED SUBCAB®, Y

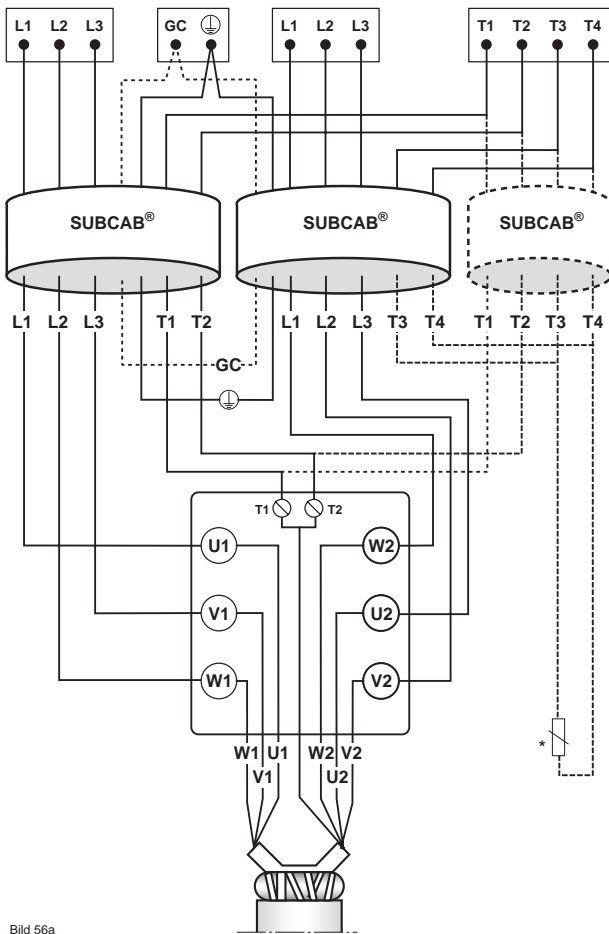

Bild 49c

Mains	SCREENED SUBCAB®	Terminal board
L1	brown	U1
L2	black	W1
L3	grey	V1
⊕	yellow/green (tube over twisted screen)	⊕
Control	Cable lead	Terminal board
T1	T1	T1
T2	T2	T2
T3	T3	3
T4	T4	4
Stator leads connection:		
Stator lead		Terminal board
U1, red		U1
W2, black		W2
V1, brown		V1
U2, green		U2
W1, yellow		W1
V2, blue		V2
*Pt100, Main bearing		

CABLE CHART

SCREENED SUBCAB®, D

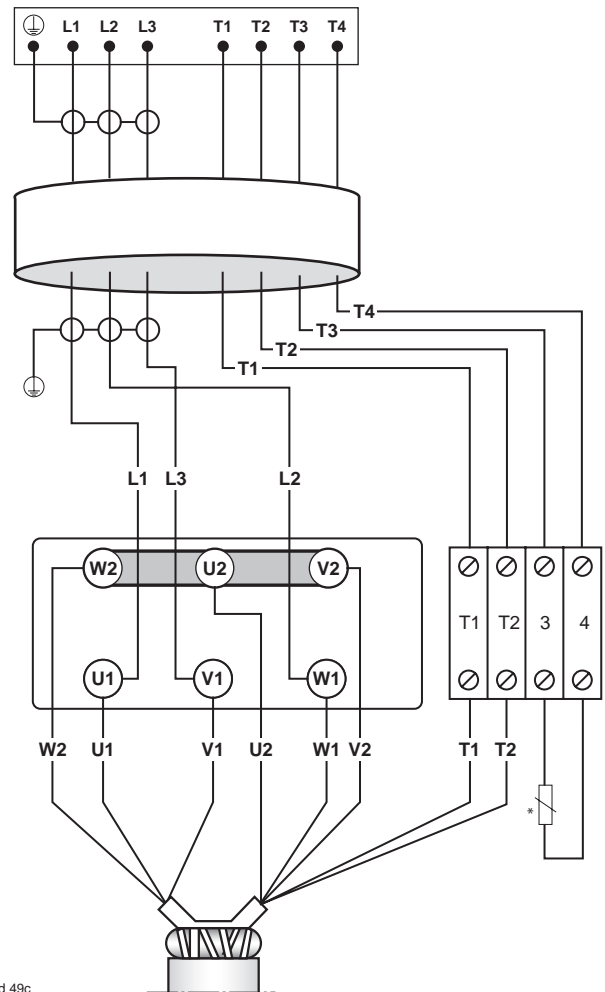

Bild 49d

Mains	SCREENED SUBCAB®	Terminal board
L1	brown	U1
L2	black	W1
L3	grey	V1
⊕	yellow/green (tube over twisted screen)	⊕
Control	Cable lead	Terminal board
T1	T1	T1
T2	T2	T2
T3	T3	3
T4	T4	4
Stator leads connection:		
Stator lead	Terminal board	
U1, red	U1	
W2, black	W2	
V1, brown	V1	
U2, green	U2	
W1, yellow	W1	
V2, blue	V2	
*Pt100, Main bearing		

SCREENED SUBCAB®, Y/D

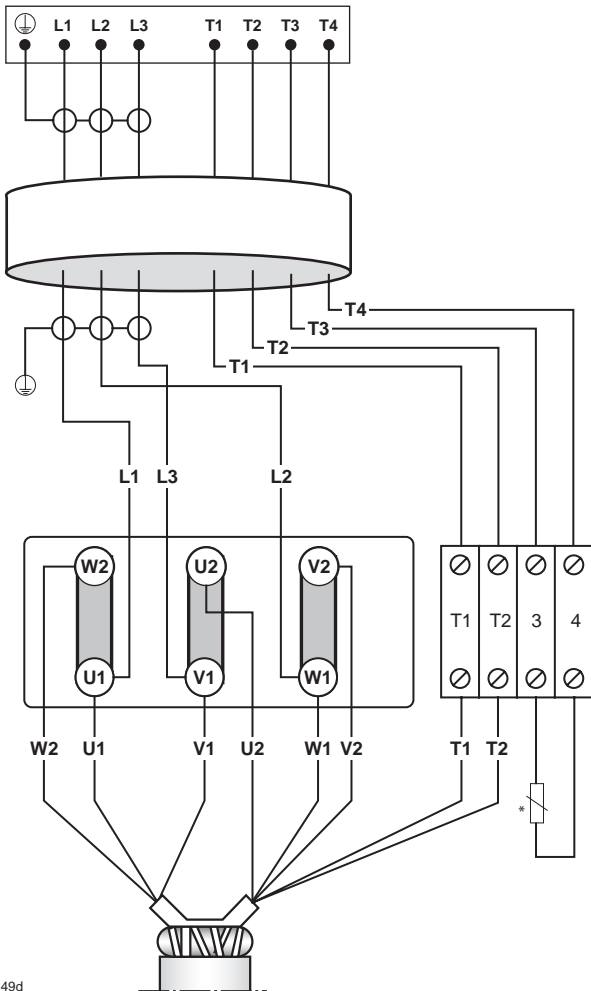

Bild 56b

Mains	SCREENED SUBCAB®	Terminal board
L1	brown	U1
L2	black	W1
L3	grey	V1
L1	brown	W2
L2	black	V2
L3	grey	U2
⊕	yellow/green (tube over twisted screen)	⊕
Control	Cable lead	Terminal board
T1	T1	T1
T2	T2	T2
T3	T3	T3
T4	T4	T4
Stator leads connection:		
Stator lead	Terminal board	
U1, red	U1	
W2, black	W2	
V1, brown	V1	
U2, green	U2	
W1, yellow	W1	
V2, blue	V2	
*Pt100, Main bearing		

OPERATION

Before starting

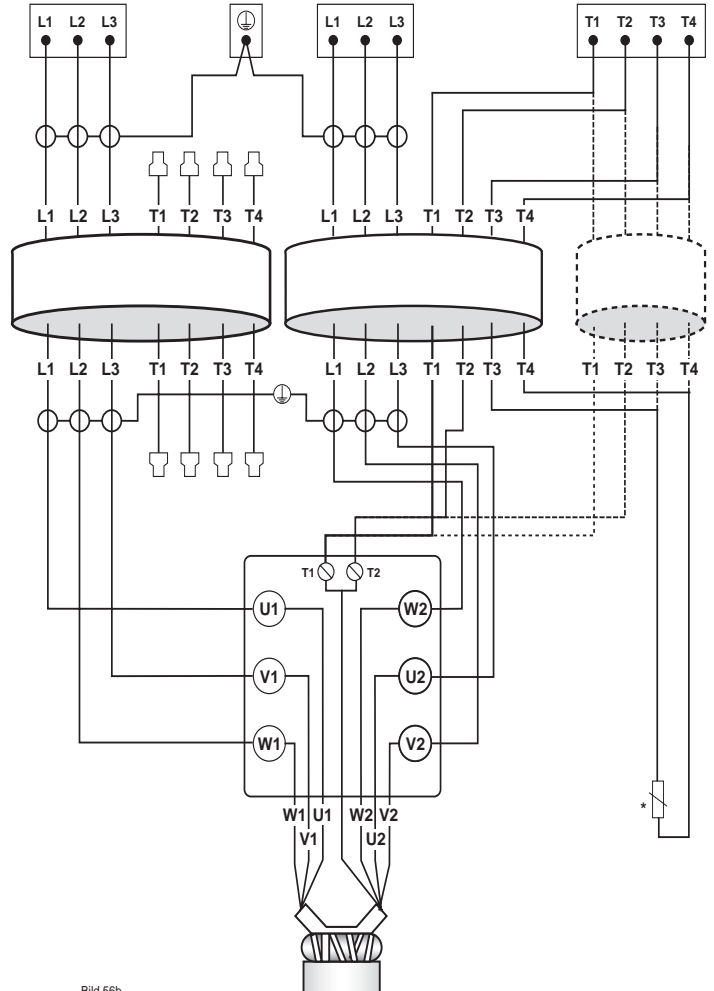
Check the oil level in the oil casing.

Remove the fuses or open the circuit breaker and check that the impeller can be rotated by hand.

Check that the monitoring equipment works.

Check the direction of rotation. The impeller shall rotate clockwise, as viewed from above. When started, the pump will jerk in the opposite direction to the direction in which the impeller rotates. See the figure.



WARNING!
Watch out for the starting jerk,
which can be powerful.

Cleaning

If the pump has been running in very dirty water, let it run for a while in clean water, or flush it through the discharge connection. If clay, cement or other similar dirt is left in the pump it may clog the impeller and seal, preventing the pump from working.

Starting jerk

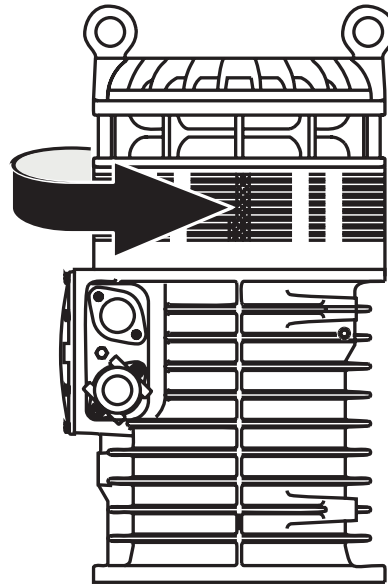

During a longer period out of operation, the pump must be test run every other month to prevent the mechanical seals from sticking together.

CARE AND MAINTENANCE

Safety precautions

The following points are important in connection with work on the pump:

- make sure that the pump has been thoroughly cleaned.
- follow local safety regulations.

In order to prevent injury to the eyes, hold a rag over the oil casing screw when removing it. Otherwise, pressure built up in the pump due to the leakage of pumped liquid into the pump may cause splatter into the eyes or onto skin.

Inspection

Regular inspection and preventive maintenance ensure more reliable operation.

The pump should be inspected at least twice a year (2000 hours), more frequently under severe operating conditions.

Under normal operating conditions, the pump should have a major overhaul in a service shop once a year. This requires special tools and should be done by an authorized service shop.

When the pump is new or when the seals have been replaced, inspection is recommended after one week of operation.



WARNING!
Before starting work on the
pump, make sure that the pump
is isolated from the power supply
and cannot be energized.

Recommended inspections:

Inspection of	Action
Visible parts on pump and installation	<p>Replace or fix worn and damaged parts.</p> <p>Make sure that all screws, bolts and nuts are tight.</p> <p>Check condition of carrying handle/lifting eyes, chains and wire ropes.</p>
Pump casing and impeller	<p>Replace worn parts if they impair function.</p>
Condition of the oil	<p>A check of the condition of the oil can show whether there has been an increased leakage. Note! Air/oil mixture can be confused with water/oil mixture. Suck up a little oil from the bottom using oil drainage pump 410 363 or the equivalent.</p> <p>Change the oil if it contains too much water, i.e., is heavily emulsified (cream-like), or if the water has settled out. See "Changing the oil". Check again one week after changing the oil. If the oil contains too much water again, the fault may be:</p> <ul style="list-style-type: none"> — that an oil screw is not sufficiently tight. — that the O-ring of an oil screw or its sealing surface is damaged. — that the mechanical seal is damaged. Contact a Grindex service shop.
Oil quantity	<div style="border: 1px solid black; padding: 5px;">  <p>WARNING! If the seal leaks, the oil casing may be under pressure. Hold a rag over the oil casing screw in order to prevent splatter. See "Safety precautions" for additional information.</p> </div> <p>Check that the oil reaches up to the oil hole when the pump is lying down with oil hole up. Add oil as needed. see "Changing the oil".</p>
Liquid in the stator casing	<p>If there is water in the stator casing, the cause may be:</p> <ul style="list-style-type: none"> — that an O-ring is damaged. — that the cable entry is leaking. <p>If there is oil in the stator casing, the cause may be:</p> <ul style="list-style-type: none"> — that the inner seal is damaged. Contact a Grindex service shop. — that an O-ring is damaged.
Cooling system	<p>Rinse and clean if the flow through the system has been partly restricted.</p>
Cable entry	<p>Make sure that the cable clamps are tight. If the cable entry leaks:</p> <ul style="list-style-type: none"> — check that the entry is firmly tightened into its bottom-most position. — cut a piece of the cable off so that the seal sleeve closes around a new position on the cable. — replace the seal sleeve. — check that the seal sleeve and the washers conform to the outside diameter of the cables.
Cables	<p>Replace the cable if the outer jacket is damaged. Make sure that the cable do not have any sharp bends and are not pinched.</p>
Starter equipment	<p>If faulty, contact an electrician.</p>
Rotation direction of pump (requires voltage)	<p>Transpose two phase leads if the impeller does not rotate clockwise as viewed from above. Rotation in the wrong direction reduces the capacity of the pump and the motor may be overloaded. Check the direction of rotation, during non-load every time the pump is reconnected.</p>
Pipes, valves and other peripheral equipment	<p>Repair faults and notify supervisor of any faults or defects.</p>

Changing the oil



WARNING. If the seal leaks, the oil casing may be under pressure. Hold a rag over the oil plug to prevent splatter.

Unscrew the oil drain screw and let the oil run out. When all oil has drained off put the oil drain screw back.

Unscerw the oil level screw as well as the oil filling screw.

Fill new oil until oil pours out from the oil level hole (approx. 11.4 litres, 12 US quarts). Place the screw back in. Tightening tourqe 10-20 Nm (7.5 15 ft lb).

A paraffin oil with viscosity close to ISO VG 15 is recommended (e.g. Mobil Whiterex 307-309). The pump is delivered with from factory with this type of oil.

In applications where poisonous properties are of less concern, a mineral oil with viscosity up to ISO VG 32 can be used.

Always replace the O-rings of the oil hole screws.

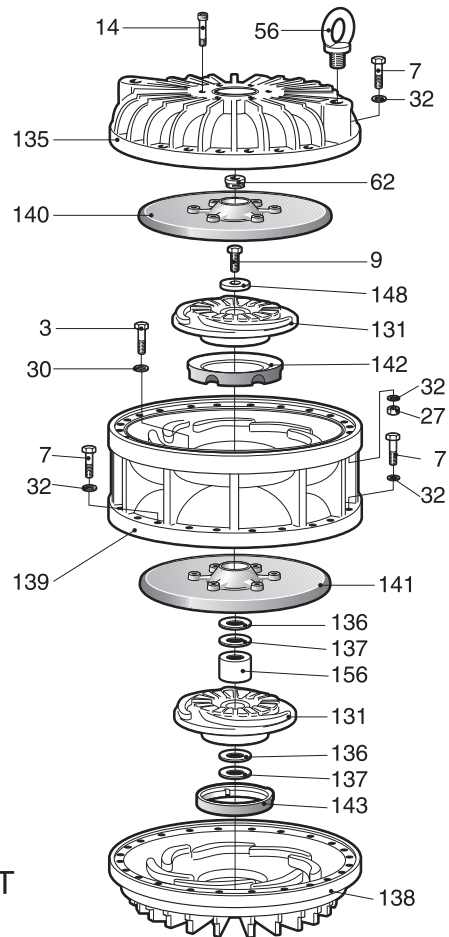

Replacing the impeller, H-version

Removing the impeller



WARNING! Worn impellers often have very sharp edges.

Unfasten the bolted joint which holds together the upper and lower rubber-coated diffuser rings (135 and 139) for the outer impeller (131).

Insert a sling into the lifting eyes (56) and lift away the upper diffuser ring. Note that the outer diffuser ring (140) follows with it.

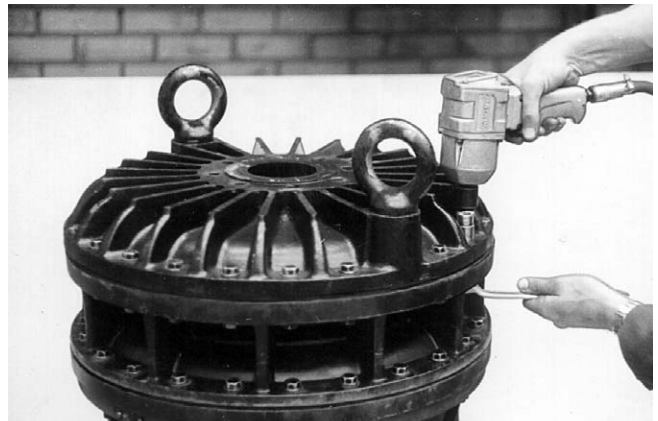

Loosen the impeller screw (9) and remove the underlying washer (148).



The impeller (131) can then be removed with the aid of two crowbars. Remove the key (1).



Remove the two strainer halves (158 and 159) by undoing their fixing screws (2). The next diffuser ring section (139) can then be lifted free after the bolted joint has been disconnected. Note that every other bolt is screwed into the oil casing (153). Use a sling as shown.

The inner diffuser disc (141) is located inside the diffuser ring (139). If it must be removed, the wear ring (142) must first be removed. This is most easily done with the aid of two screwdrivers. The screw (3) which holds the diffuser disc (141) is then rendered accessible



Take off the sleeve (156).

If it is tight, use a puller. It may come loose when the inner impeller (131) is prized loose in the same way as the outer.



Lift off the diffuser ring (138) and then the adjustment washers (136 and 137) for the impeller.

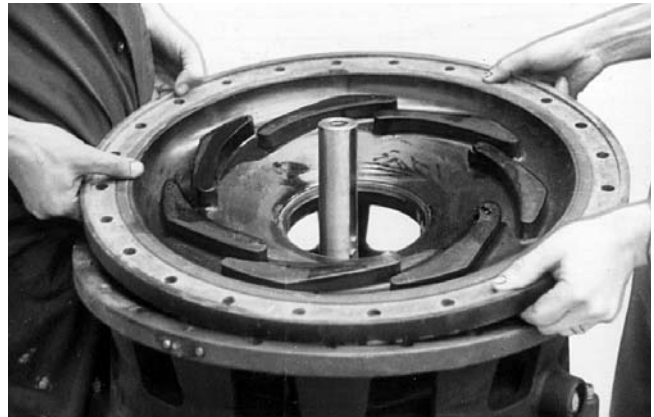

Installing the impeller

Start by fitting a key (1) in the innermost keyway on the shaft, and any necessary adjusting washers (136,137).



Then place the rubber-coated diffuser ring (138) in position, and tighten it temporarily with a few bolts (7) so that it is properly positioned, which is important for the following impeller adjustment.



Fit the inner impeller (131).

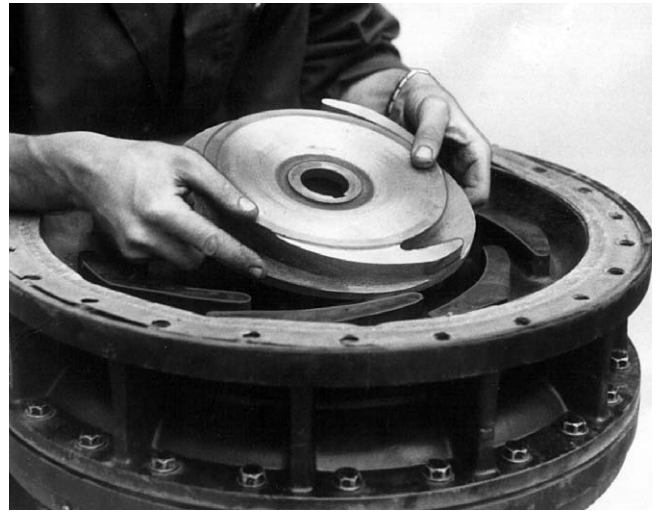

Slip the sleeve (156) onto the shaft.
Now fit the diffuser disc (141) into the diffuser ring (139), which must be located between the two impellers.



Apply the adjusting tool 51 279 00 to the diffuser ring as shown below. Tighten so that the screw on the tool just touches the diffuser disc (141).

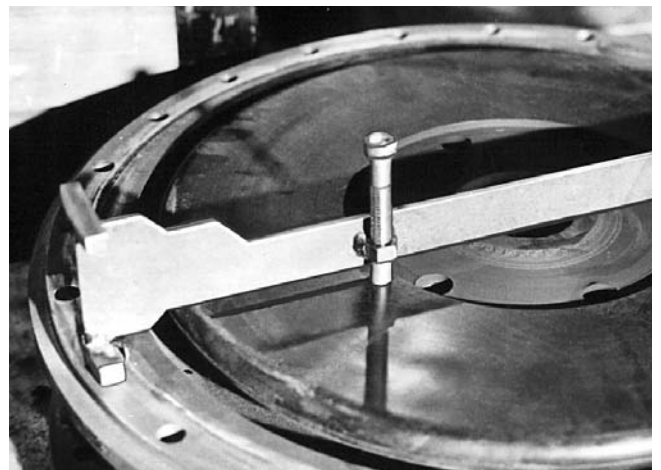

Place the assembly sleeve 51 280 00 over the shaft up against the impeller (131) and tighten by means of the impeller screw (9). Tightening torque 200 Nm (147 ft.lb.). Use a torque wrench. The assembly sleeve 51 280 00 is used to give the adjusting washers the right thrust.

Now move the sealing tool 51 279 00 from the diffuser disc to the impeller while turning the tool 180° without disturbing the position of the screw. Put the tool down and check that the clearance between the head of the screw on the tool and the impeller is 0.1-0.2 mm (0.004"-0.008"). Otherwise adjust using the adjusting washers (136 and 137) underneath the impeller.

Now remove the assembly sleeve 51 280 00. Fit the diffuser ring (139) with its diffuser disc (141). Tighten the bolts (7).

Repeat the same procedure to adjust the outer impeller (131), but without using the assembly sleeve 51 280 00.



When fine adjustment is finished, fit the top diffuser ring (135).

Then check the fine adjustment by using a socket, an extension bar and a handle. Place the socket on the impeller screw and turn the entire shaft with impellers around a few times to check that the impellers are not rubbing against the diffuser rings.

Then fit the screw plug (62) in the diffuser disc (140).

In order for the pump to perform at maximum capacity, the impeller must be adjusted regularly.

It is particularly important that the clearance is between the lower diffuser and the impeller is kept to a minimum.

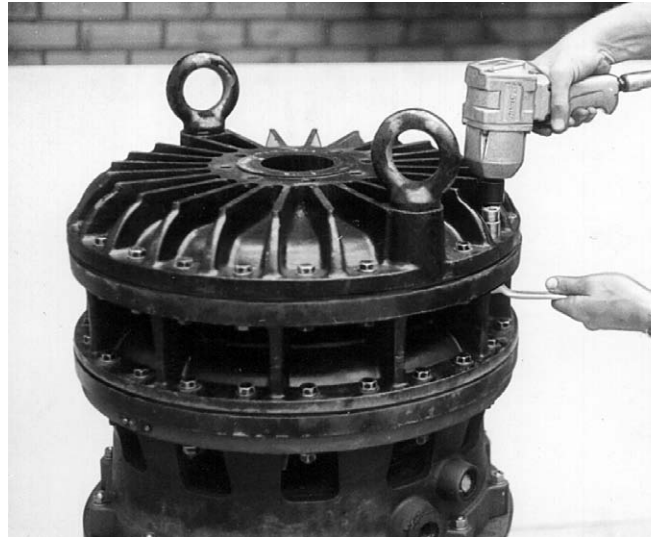

Replacing the impeller, N version

Dismantling



WARNING! Worn impellers often have very sharp edges.

First remove the strainers (160).

Remove the outer suction cover (132) and the impeller (131), if necessary with the aid of a three-shanked puller.

Undo the screws (6) that retain the pump casing (130).

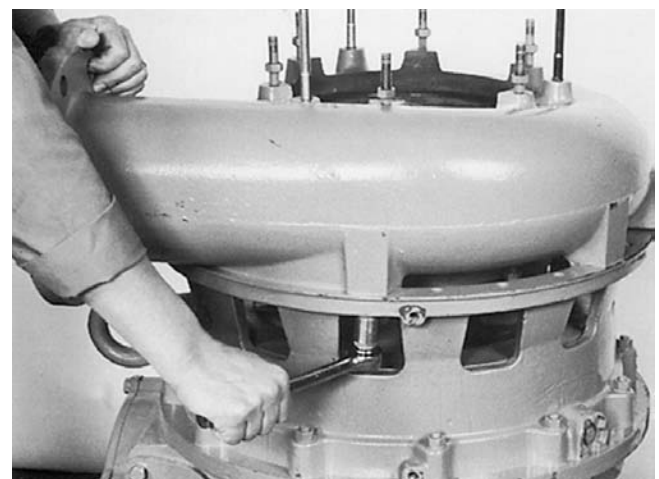
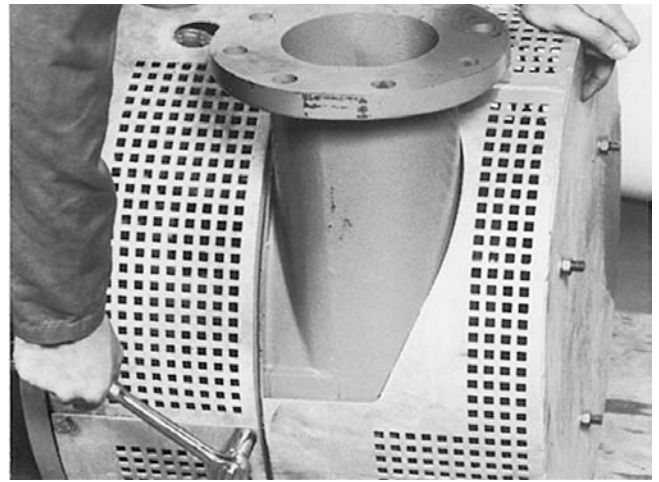

Remove the pump casing with the inner suction cover (132).

Then detach the inner suction cover (132) from the pump casing. Remove the keys from the shaft.

Otherwise proceed as for the H version.



N version

Reassembly

Start by fitting the sleeve (156) and the keys onto the shaft.



Fit the inner suction cover (132) onto the pump casing (130). Check that the O-ring (49) is in place.

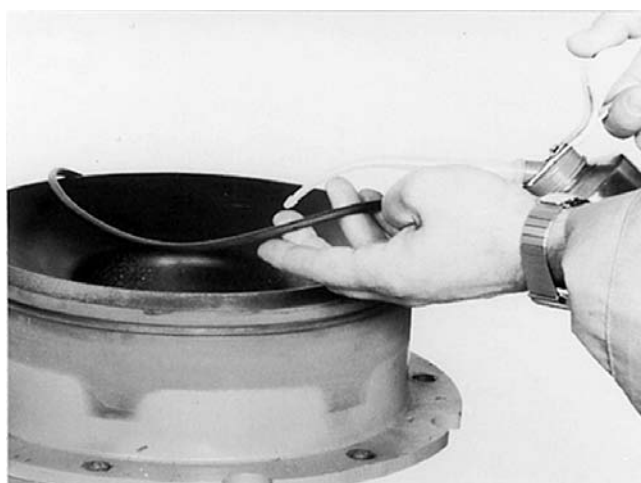

Position the suction cover (132) in the withdrawn position so that the outer nuts (27) engage a few threads.



Then fit the pump casing (130) with its screws.

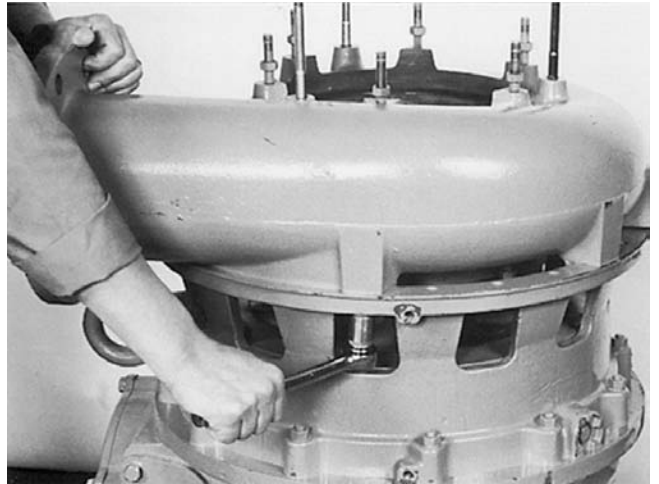

Now mount the impeller (131) with the longer hub end facing towards the motor. Check that the impeller is in the middle of the pump casing. Adjust if necessary with adjusting washers. Tighten the impeller to 200 Nm (150 ft lb). Use torque wrench.

Then fine adjust the inner suction cover against the impeller using the nuts (27) so that a minimum and uniform clearance is obtained between the impeller and the suction cover.

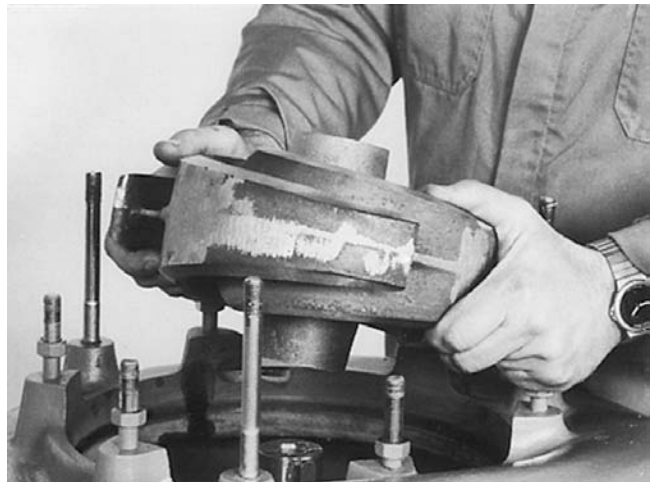

Fit the outer suction cover (132) and fine-adjust it against the impeller using the nuts (27) so that a minimum and uniform clearance is obtained between the impeller and the suction cover.

Use a socket, extension bar and handle on the impeller screw (9). Turn the shaft around during fine adjustment to make sure it is not seizing anywhere.

Fit the strainers.

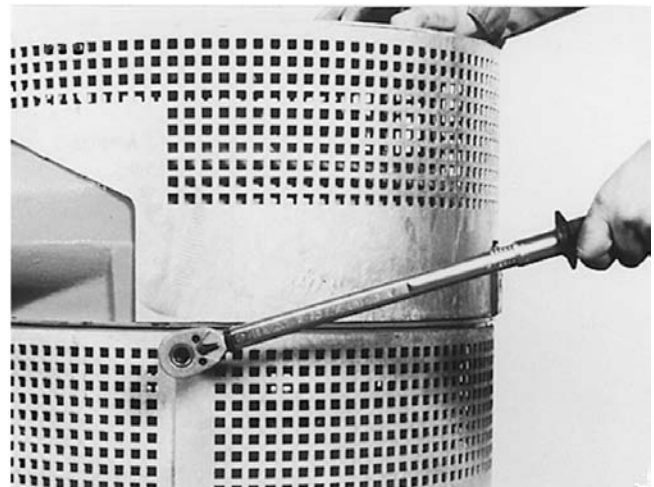
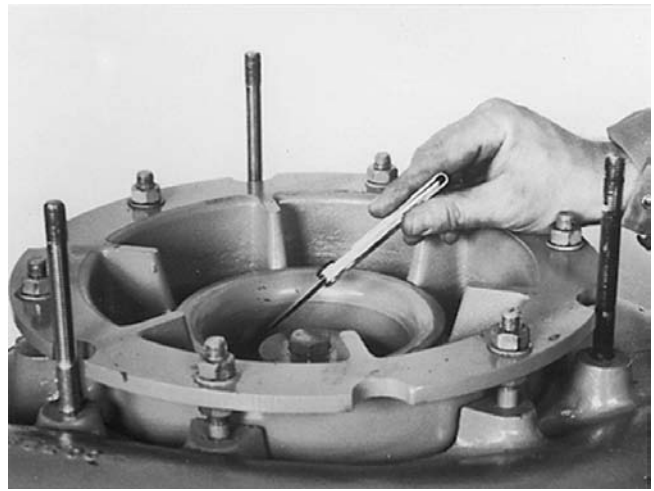

NOTE!

For major overhaul instructions please refer to the workshop manual for this product or contact your local Grindex representative.

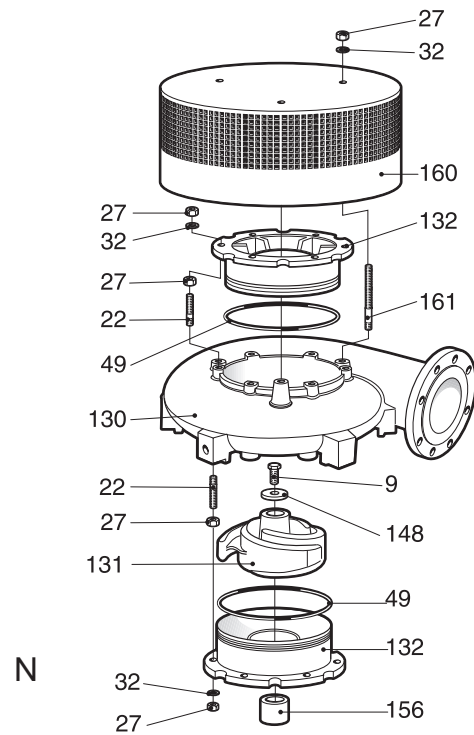

FAULT TRACING (TROUBLESHOOTING)

A universal instrument (VOM), a test lamp (continuity tester) and a wiring diagram are required in order to carry out fault tracing on the electrical equipment.

Fault tracing shall be done with the power supply disconnected and locked off, except for those checks which cannot be performed without voltage.

Always make sure that there is no one near the pump when the power supply is turned on.

Use the following checklist as an aid to fault tracing. It is assumed that the pump and installation have formerly functioned satisfactorily.

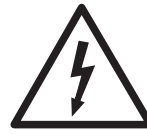

Electrical work shall be performed by an authorized electrician.

Follow local safety regulations and observe recommended safety precautions.

1. Pump fails to start

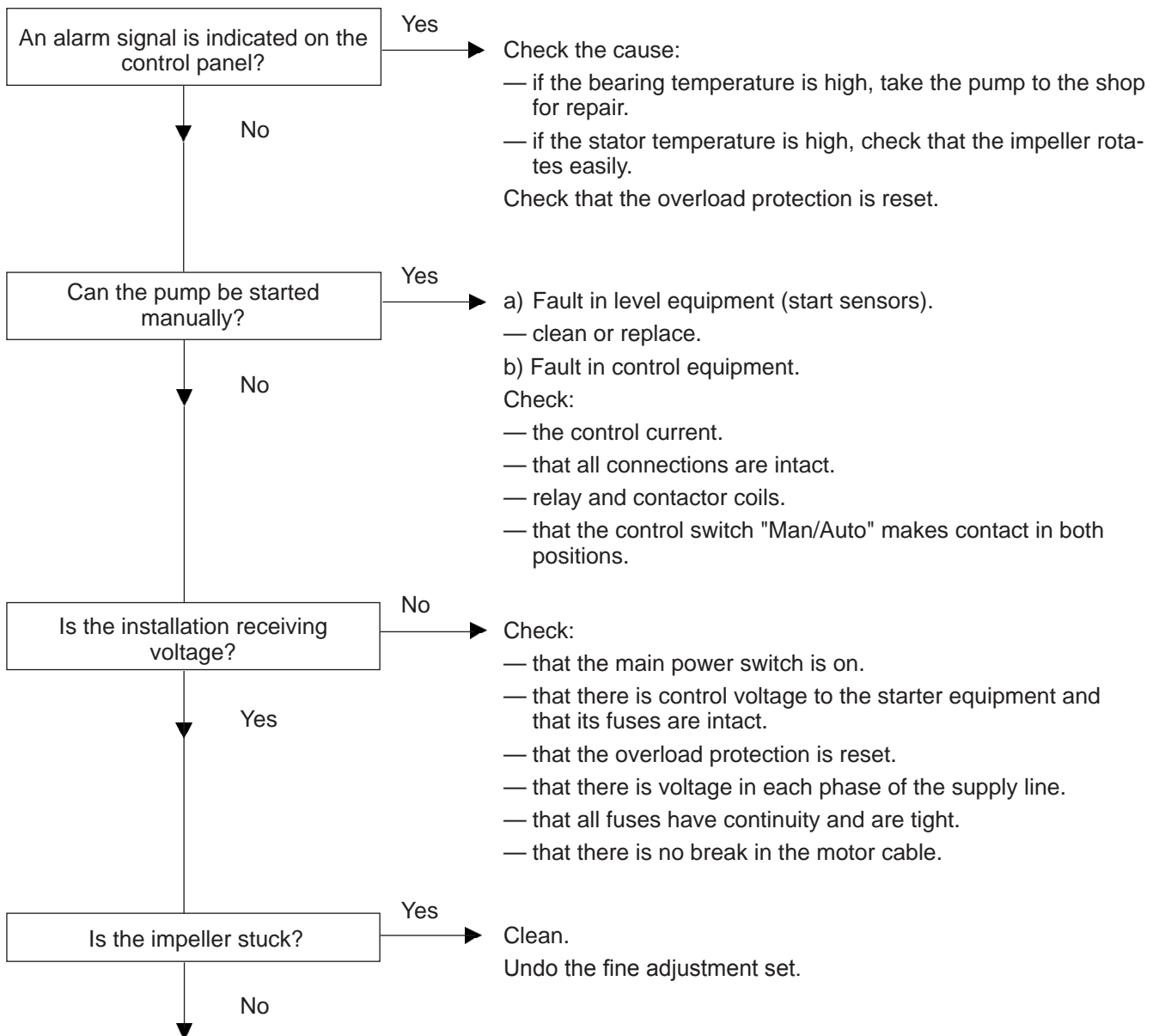

Contact Grindex service shop.



WARNING: disconnect power before checking the impeller.

2.Pump starts but motor protection trips

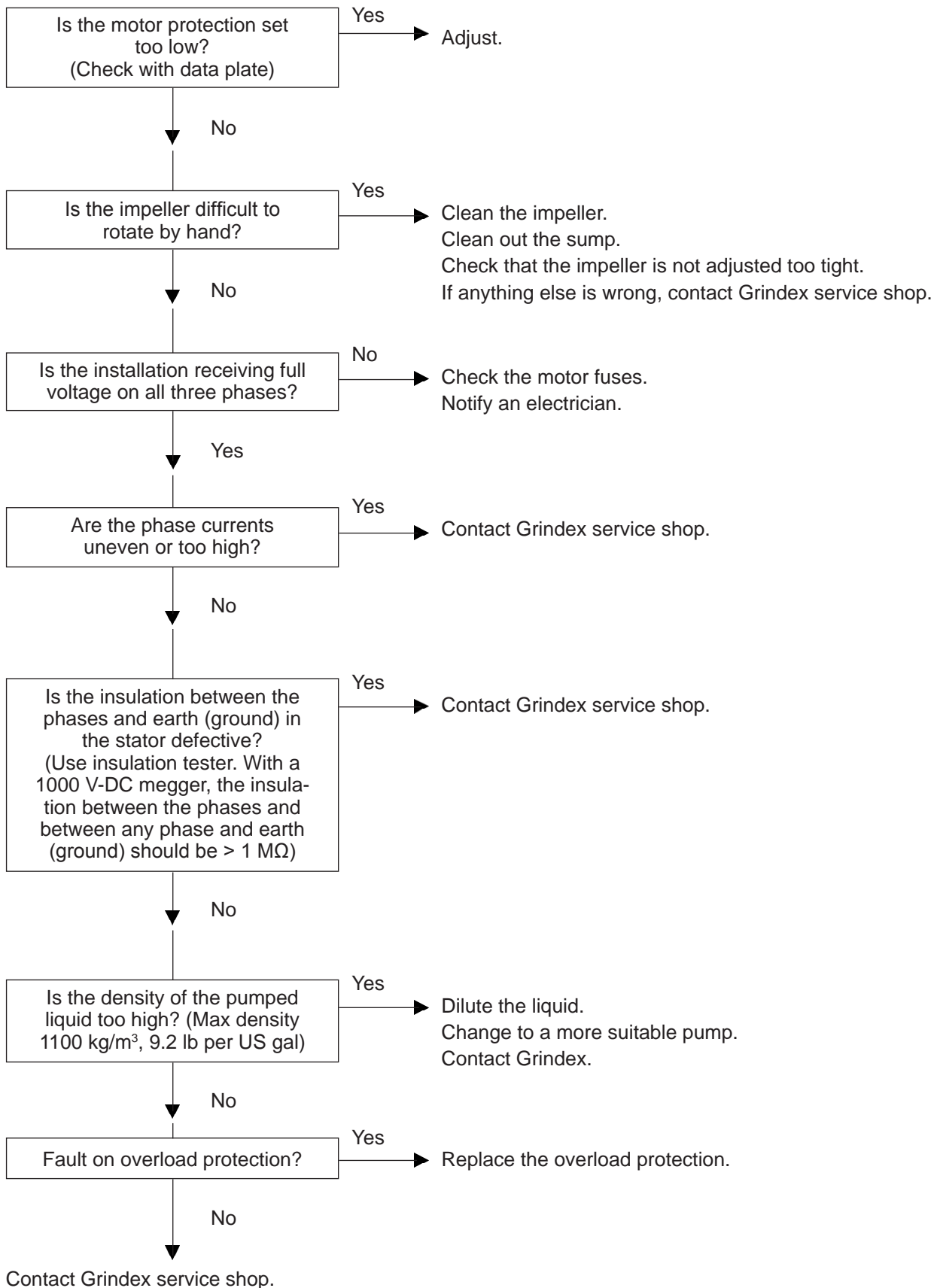

3.The pump does not stop (when level control is used)

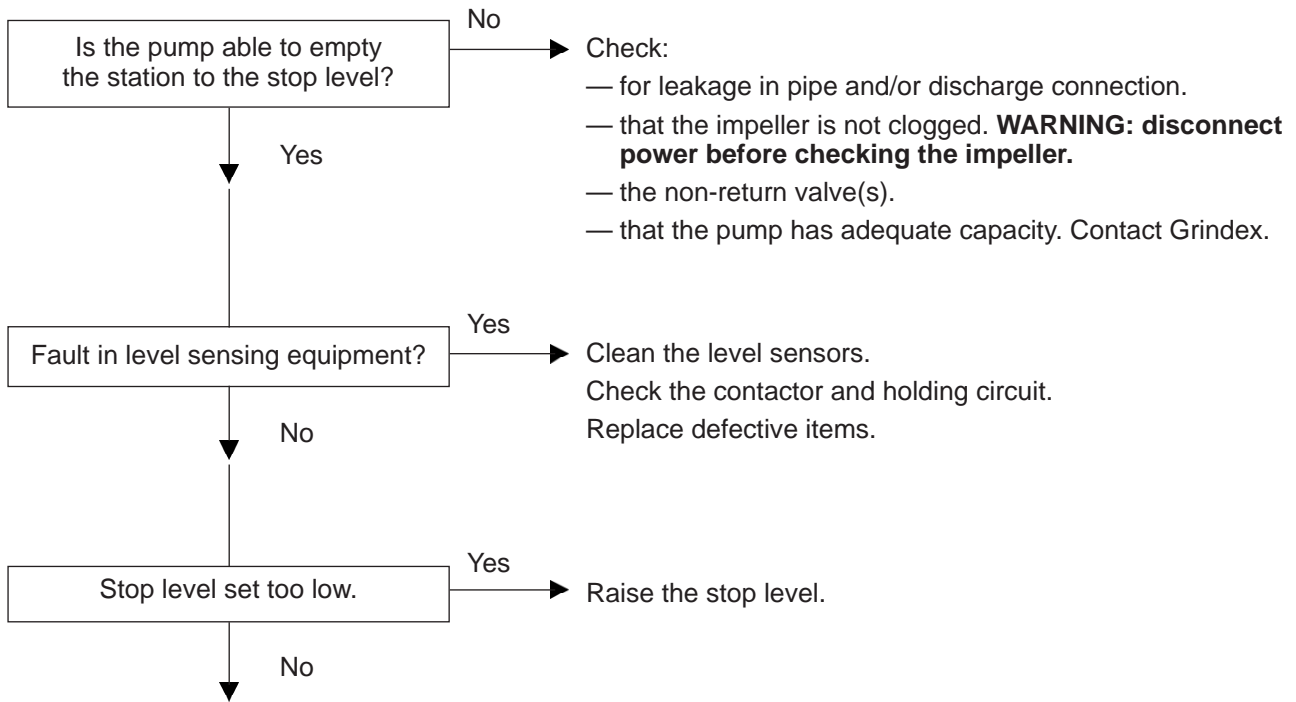

Contact Grindex service shop.

4.The pump starts-stops-starts in rapid sequence

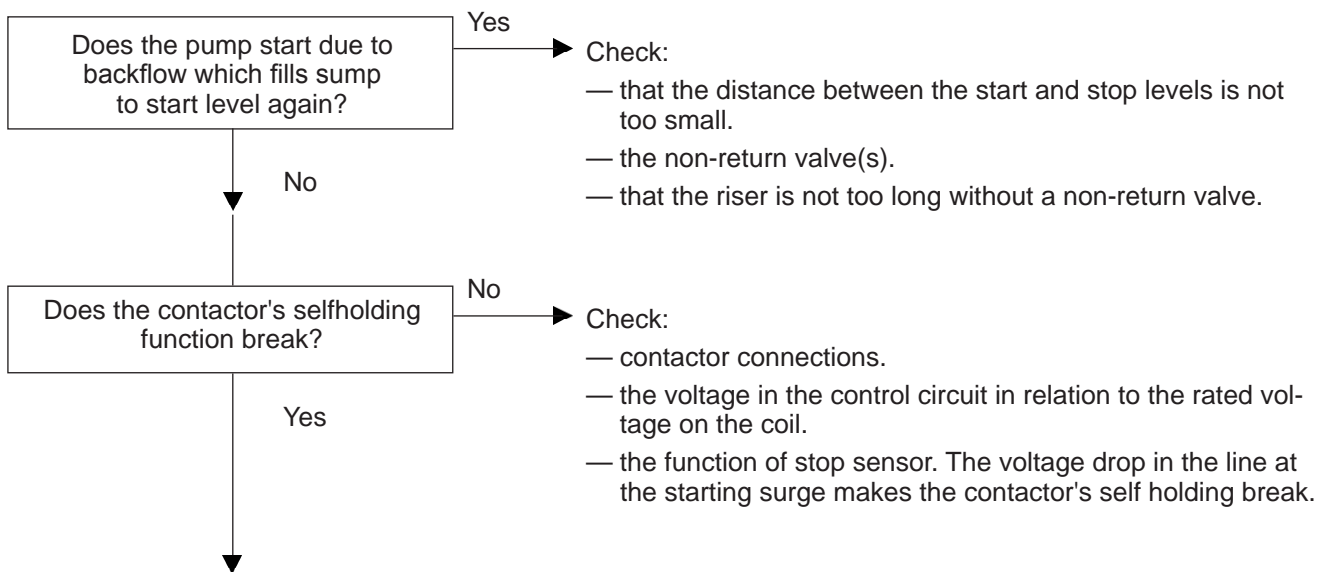

Contact Grindex service shop.



5.Pump runs but delivers too little or no water

Check:

- direction of rotation of pump, see “Before starting”.
- that valves are open and intact.
- that pipes, impeller and strainer are not clogged.
- that the impeller rotates easily.
- that the suction lift has not been altered.
- for leakage in the pump installation.
- for wear on wear protection, impeller, pump casing, suction cover, oil casing.

See also under “Inspection”.

Do not override the motor protection repeatedly if it has tripped.

ACCESSORIES AND TOOLS

Tools

Besides ordinary standard tools, the following tools are required in order to perform the necessary care and maintenance of the pump:

Article No.	Description
410 363	Oil pump
-	Handle
-	Combination wrench across flats = 19 mm
-	Socket across flats = 19 mm
-	Socket across flats = 24 mm
-	Extension bar 250 mm
-	Torque wrench 50–225 Nm
51 280 00	Assembly sleeve (for fine adjustment of HT)
51 279 00	Fine-adjusting tool (HT)

Zinc anode set

In order to reduce corrosion on the pump, it can be fitted with zinc anodes.

Article No.	Description
51 117 00	For N-version
51 117 05	For H-version

SERVICE LOG

Most recent service date	Pump No.	Hours of operation	Remarks	Sign.



Grindex AB • Box 7025 • 174 07 Sundbyberg • Sweden • Tel +468 606 66 00 • Fax +468 745 53 28 • marketing@grindex.com