



Submersible heavy-duty pump for very high head applications in mines, quarries and tunnel projects.



**Drainage pump:**

Mega

60 Hz



## Mega - the drainage pump for very high head applications

The Mega pump is ideal for operation in deep excavations where very high head pumping is needed, such as in open pit mines as well as in underground mines. Other typical applications include quarries and tunnelling projects.

Mega is designed to handle pH levels from 6 to 13; zinc anodes are available for extra protection. As this pump is made of cast iron, it is also the right choice for heavy-duty applications in salt water. Grindex reliable pumps are designed for long time operation and are easy to install.

Just like Grindex pumps spend most of their life hidden below the water surface, the greater part of total pumping cost is usually also hidden. A Grindex pump drains the water, not the budget.

All Grindex pumps are designed for continuous, unattended operation. For 50 years, they have proven their reliable performance in a wide range of challenging applications worldwide.

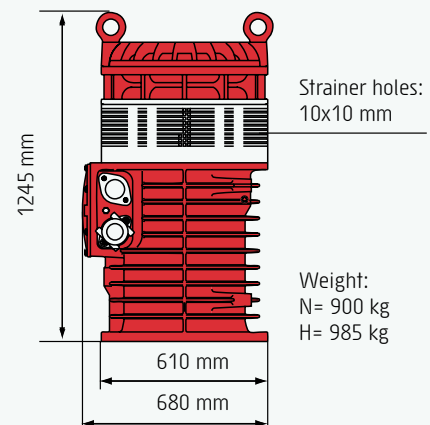



## TECHNICAL DATA

### Pump types

N: Normal head  
H: High head

### Classification

Electrical submersible pump  
Protection class: IP68

### Electrical motor

Squirrel cage 3-phase induction motor  
Insulation class: H (IEC 85)

### Motor protector

Temperature guard with thermal contacts in the stator

### Monitoring equipment

Pt 100 sensor for main bearing temperature reading

### Power cable

SUBCAB, consult product data sheet for details

### Shaft seals

Double mechanical shaft seals with an oil compartment between the seals.

Material lower seal: Tungsten carbide - Tungsten carbide

Material upper seal: Tungsten carbide - Tungsten carbide

### Bearings

Main bearing: Two single-row angular contact ball bearing  
Support bearing: Cylindrical single-row roller bearing with C3 clearance

### Discharge connections

N: 6" (DN 150) Flange SMS, DIN, BS or ANSI

H: 4" (DN 100) Flange SMS, DIN, BS or ANSI

### Materials

Casted parts: Cast iron

Motor shaft: Stainless steel

Impeller: Cr-alloyed white cast iron or stainless steel

Screws and nuts: Stainless steel

Diffusers: Nitrile rubber

### Accessories

Zinc anodes

Limitations

Max. submersion depth: 75 m

Max. liquid temperature: 40°C

Max. liquid density: 1100 kg/m<sup>3</sup>

pH of the liquid: 6-13

Technical data	N	H
Rated output	104 kW / 140 HP	104 kW / 140 HP
Max. power cons.	110 kW / 147.5 HP	110 kW / 147.5 HP
Shaft speed	3560 RPM	3560 RPM
Rated current A at 460 V	149 A	149 A

Other voltages on request

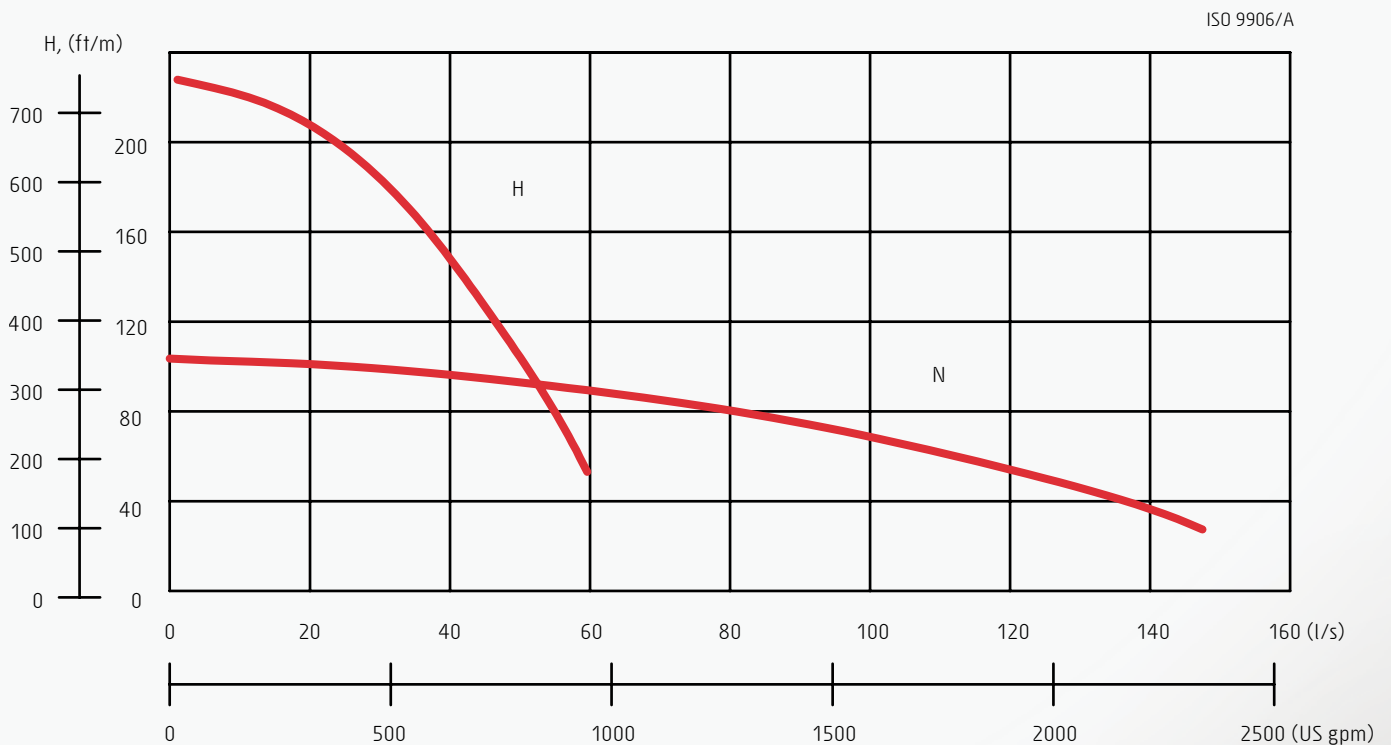



## The Grindex team.

For some 50 years, Grindex has specialised in designing and manufacturing electrical submersible pumps for professionals. Durable and dependable, they are used in the most demanding and specialised applications worldwide. We have delivered over 300 000 pumps in more than 100 countries.

We offer pumps for almost any application. Our range includes drainage pumps, sludge pumps, slurry pumps and stainless steel pumps.

When you are running a Grindex pump, you can rest assured that a dedicated team is watching your back. Our experts are always there to see to your every need. Through our global network of sales and service centres, we provide the best level of support possible – day and night, seven days a week.

It's all part of the service.

For more information, please visit [www.grindex.com](http://www.grindex.com)